

Development of a 1 GS/s High-Resolution Sampling ADC System

S. Bartknecht, H. Fischer, F. Herrmann, K. Königsmann, L. Lauser, C. Schill, S. Schopferer, H. Wollny
 Universität Freiburg, Physikalisches Institut, 79104 Freiburg, Germany

The Compass Experiment @ CERN

Generalized Parton Distributions

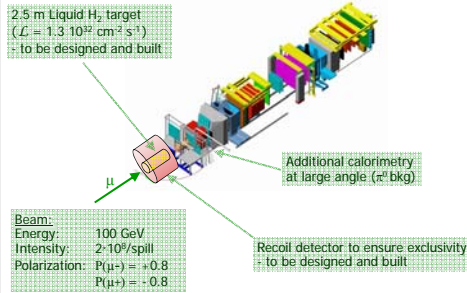
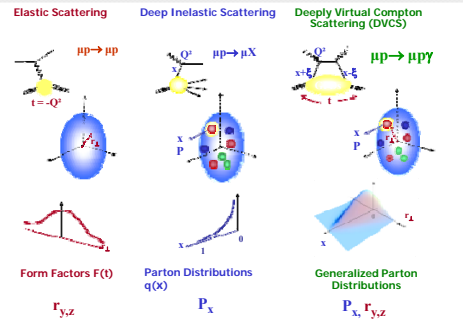

Recoil-Proton Detector

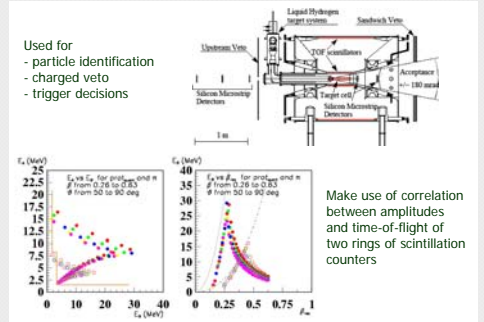

Analog Input

- Single ended DC-coupled inputs
- Input impedance 50 Ω
- Dynamic range -4V
- Bandwidth 500MHz
- $\pm 2V$ programmable Baseline offset with 16 bit DAC

The GANDALF Readout System

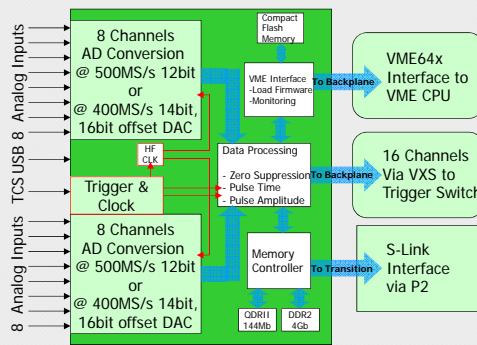

Backplane I/O

- VME64x
- Firmware
- Monitoring
- VXS
 - 16 high speed connections to trigger electronics
- Data I/O optional via
 - S-Link
 - Ethernet
 - VME64x (640 Mbit/s block r/w)
 - USB 2.0

Experiment Clock & Trigger

- Experiment clock
- Synchronization of front-ends
- Trigger distribution

Time interval error:

Requirement

Result

ADC Mezzanine Card

- 12 or 14 Bit digitization
- 8 channels 1 GS/s (interleaved)
- 16 channels 500 MS/s

Digitization error as function of analog input frequency

Data Processing

- Time resolution as function of pulse amplitude and constant fraction:
- Online zero suppression
- Pulse analysis
- Pulse time
- Pulse amplitude
- Pile-up free double pulses
- Time resolution as function of pulse amplitude:



- The GANDALF Readout System – a versatile and highly cost efficient digitization tool for nuclear, particle and atomic physics experiments
- System applications as:
 - self-triggered high-resolution sampling ADC
 - 128 ch TDC (100ps)
 - 128 ch Scaler (250 MHz)
 - 256 ch Trigger Matrix Board